

POWERED BY
VacuFlush
TECHNOLOGY



4806



4809, 4848

4800 SERIES VACUFLUSH® TOILETS INSTRUCTION MANUAL

IMPORTANT NOTICE

VacuFlush® sanitation systems must be installed according to Dometic's recommended procedures. Do not attempt installation without first contacting a VacuFlush® certified dealer or Dometic Corporation.



WARNING

This manual must be read and understood before adjustment, maintenance, or service is performed. Modification of this product can result in property damage.

SYSTEM SPECIFICATIONS

Water Supply	Water hose connection	Thread size	1/2 inch MPT
		Flow rate at toilet	2 GPM/7.6 LPM
Discharge Piping	Hose ID	Standard	1.5 inch/38 mm
	Hose runs	Max. horizontal run	50 ft./15 m*
		Max. vertical run	6 ft./1.8 m*
Electrical System	Amp draw (avg.)	12 volts DC	2.0 amps
		24 volts DC	1.0 amp
	Circuit breaker	12 volts DC	2 amps**
		24 volts DC	2 amps**

* See page 8 for further information.

** Each toilet must be on separate circuit breaker. Does not include electrical requirements of vacuum pump.

TABLE OF CONTENTS

Product Features	1	Proper Bowl Cleaning	6
System Specifications	1	Clearing Discharge Lines	6
Toilet Specifications and Dimensions	2	Winterizing	7
Toilet Model Identification	3	Maintaining the System	7
Warnings	3	Spare Parts	7
Toilet System Components	4	Ordering Parts	8
Marine Sanitation Regulations	4	Installation - General Information	8-10
Important Information Before Operation	5	Deodorants and Special Tissue	10
System Start-Up	5	Troubleshooting Guide	11-15
Toilet Operation	5	Customer Service and Warranty	16
Service Mode	6		

TOILET SPECIFICATIONS

Model	Description	Weight
4806	All-ceramic, low-profile vacuum toilet with full-size seat and bowl. Through-floor discharge.	42 lbs. (19 Kg)
4809	All-ceramic, standard height vacuum toilet with full-size seat and bowl. Through-floor discharge.	50 lbs. (22.7 Kg)
4848	All-ceramic, standard height vacuum toilet with full-size seat and bowl. Above-floor discharge.	50 lbs. (22.7 Kg)

Weights may vary \pm 2-3%. Specifications subject to change without notice.

DIMENSIONS

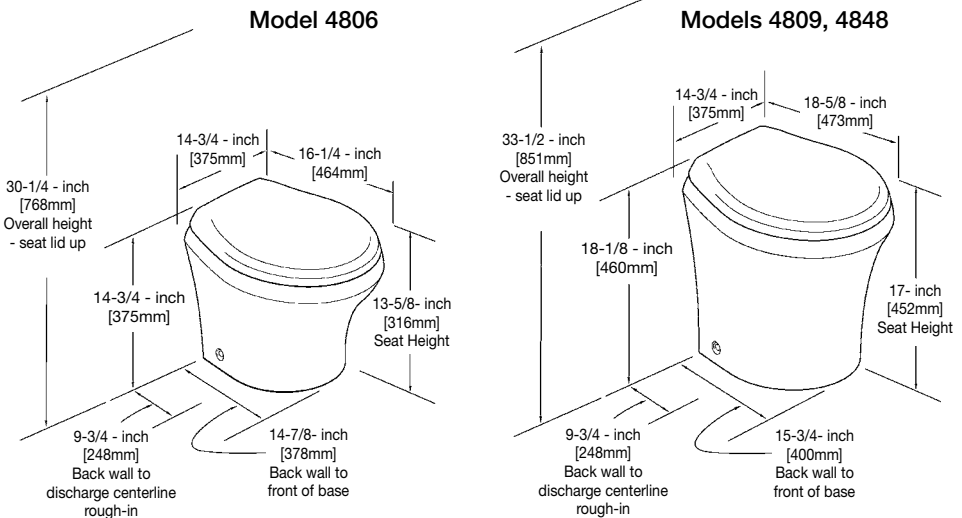

All dimensions may vary \pm 3/8-inch (10mm).

TOILET MODEL IDENTIFICATION

The model identification label is located on the back of the toilet. It shows the model number and serial number of the product.

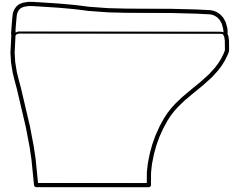

WARNINGS

Dometic vacuum toilet systems must be installed according to Dometic's recommended procedures. Dometic also recommends that a qualified marine technician or electrician install or service this product. Equipment damage, injury to personnel or death could result from improper installation. DOMETIC SANITATION CORPORATION ACCEPTS NO RESPONSIBILITY OR LIABILITY FOR DAMAGE TO EQUIPMENT, OR INJURY OR DEATH TO PERSONNEL THAT MAY RESULT FROM IMPROPER INSTALLATION, SERVICE OR OPERATION OF THIS PRODUCT.



WARNING!

HAZARD OF FLOODING – If the toilet system is connected to ANY through-the-hull fittings, properly installed seacocks MUST be installed in all piping connected to through-the-hull fittings. Seacocks MUST be easily accessible to all users of the toilet system or secondary valves fitted in hoses where they are easily accessible. ALWAYS close seacocks when toilet system is not in use (even if boat is unattended for a brief period). All valves MUST be full bore valves and marine quality. Screw-to-close gate valves are not recommended. Failure to comply can result in flooding which can cause loss of property and life.



WARNING!

HAZARD OF FLOODING – If toilet is connected to ANY through-the-hull fittings, ALL flexible hoses must be of marine sanitation quality and must be secured to ANY fittings (such as those at seacock, vented loop or toilet) with two stainless steel, worm-drive hose band clamps at each connection. Connections MUST be checked frequently for integrity. Failure to comply can result in flooding which can cause loss of property and life.



WARNING!

HAZARD OF FLOODING – If toilet rim is below the waterline at ANY time (during any conditions of heel, load or trim) and is connected to ANY through-the-hull fittings, properly positioned ventilated (vented) loops MUST be installed in intake* or discharge piping to prevent potential back siphonage of seawater into the boat. Failure to do so can result in flooding which can cause loss of property and life.

* if connected to raw water



WARNING!

HAZARD OF FLOODING – If the toilet uses fresh water for flushing and is connected directly or indirectly to a shoreside municipal water system at ANY time, shoreside water connections MUST be disconnected if the boat is unattended (even for a brief period). Failure to comply can result in flooding which can cause loss of property and life.



WARNING!

HAZARD OF FLOODING – If toilet uses raw water for flushing at ANY time, a raw water pump controlled by an automatically operating demand switch MUST NOT be installed. If the onboard water valve or any plumbing connections were to leak, the automatically operated pump would start and could flood the boat. Failure to comply can cause loss of property and life.



WARNING!

HAZARD OF FLOODING – Before beginning any work on this product, be sure that all electrical power to the unit has been turned off. Failure to do so can result in flooding which can cause loss of property and life.



WARNING!

HAZARD OF SHOCK OR FIRE –

Always use recommended fuse, circuit breaker and wire size. Failure to do so can result in fire that can cause the loss of property and life.



CAUTION:

Overfilling the holding tank can create serious damage to the sanitation system, such as rupturing the holding tank and releasing tank contents into the bilge. To prevent this possibility, Dometic strongly recommends the addition of a “full” tank safety shut-down relay to the toilet's incoming electric power wiring. The “full” signal from the holding tank can be generated by an optional Dometic Tank Monitor system.

TOILET SYSTEM COMPONENTS

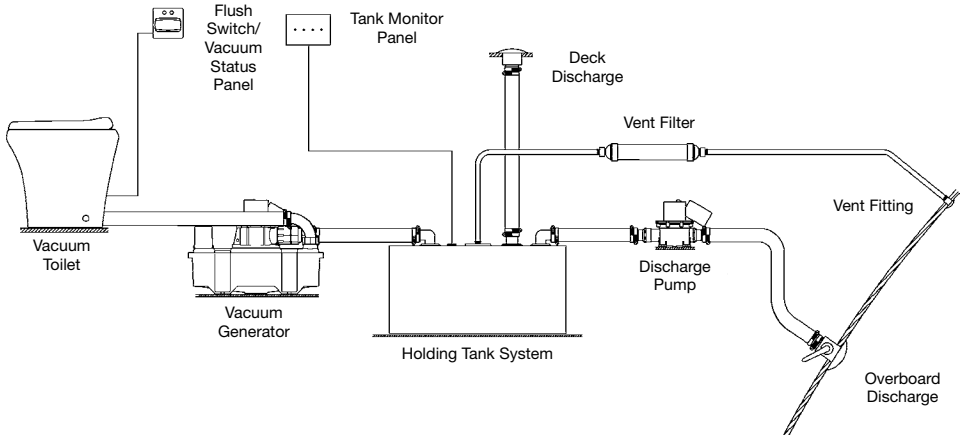

A VacuFlush 4800 series toilet is part of a total sanitation system that includes a vacuum source and usually a holding tank. Because of the wide variation of boat types and models, Dometic produces a wide range of vacuum-generating components, holding tanks and accessories. The VacuFlush system diagram (above) provides a general orientation to a typical vacuum sanitation system.

Vacuum Source: A variety of Dometic vacuum sources provide vacuum energy to move the waste from the toilet to the holding tank. All consist of a vacuum storage reservoir and vacuum pump. These can be separate or combined units (vacuum generators).

Holding Tanks: Many boats are equipped with a holding tank, and many of those are SeaLand holding tank systems. SeaLand tanks are available in many capacities, and can include pre-installed vacuum generator, tank level monitor, discharge pump, and other accessories to enhance the comfort and convenience of marine sanitation.

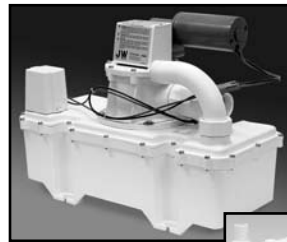

**J-Series
Vacuum
Generator**



**S-Series
Low-profile
Vacuum
Generator**

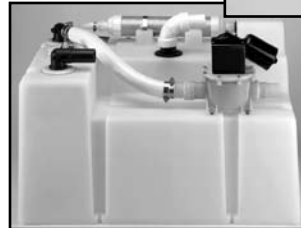

**28HTS-T
Holding
Tank**

MARINE SANITATION REGULATIONS

All boats with fixed toilets in U.S. waters and in the waters of some other countries are required to have an operable marine sanitation device (MSD). The VacuFlush vacuum sanitation system, when installed in a boat, is a holding tank or Type III system as defined by the U.S. Coast Guard. Type III systems permit operation of the toilet without direct discharge of untreated waste after every flush. Type III systems can be discharged at marina dockside pump-out stations or, if in coastal waters, a minimum of three miles offshore. **Overboard discharge capability must remain secured while within the three-mile limit.** The overboard discharge pump is activated by a keyed switch in the toilet compartment. **This key should be removed at all times except when discharge pump is operating.**

Sewage from any source should not be discharged directly into our waters. If you are interested in learning more about this issue, please visit our website at www.DometicSanitation.com.

IMPORTANT INFORMATION BEFORE OPERATION

1. Make sure all guests understand toilet and seacock operation and that the flushing instruction label is easy for guests to read. The label is located under the seat.
2. Remember, the vacuum pump starts automatically. Shut off electrical power to the toilet system before servicing and do not leave the boat with the toilet system electrical power on.
3. Never use solvents, alcohol, chlorine or caustic chemicals, such as laundry bleach or drain-opening types, in the toilet system.
4. If the toilet system does not operate properly, refer to the Troubleshooting section and repair as necessary. If problem persists, contact your local VacuFlush dealer or see the Customer Service section of this manual.



Label located under toilet seat.

SYSTEM START-UP

1. Fill freshwater tank.
2. Turn on electrical power and water supply to toilet system.
3. Flush water into system by flushing the toilet five times (press Flush switch and allow each flush cycle to complete until vacuum pump stops, about 60-90 seconds each).

TOILET OPERATION

1. Adding More Water To Toilet Bowl

Press Add Water switch until desired water level is attained. Do not overflow toilet bowl. More water is usually added only when flushing solids.

2. Flushing The Toilet

Press the Flush switch down for a moment, then release it. Flush only when the panel's green "OK to Flush" light is on. Some models will not flush unless the "OK to Flush" light is on. It takes about one minute for vacuum to recharge to the proper level for the next flush.

If the red "Do Not Flush" light is lit, the system is either recharging the vacuum to the proper level, or the holding tank is full. Do not flush the toilet during these conditions or system clogs may occur.

3. DO NOT FLUSH FOREIGN OBJECTS

CAUTION! VacuFlush toilets are designed to flush only water, bodily wastes and rapid-dissolving toilet tissue. Do not flush wet wipes, sanitary napkins, condoms, diapers, razor blades, paper cups, cotton swabs, food, hair or liquids such as oils or solvents. Clogging or damage to the toilet or sanitation system may occur.



Standard 4800 Flush Switch



- To **Add Water** to bowl, press left side of switch.
- To **Flush**, press right side of switch.

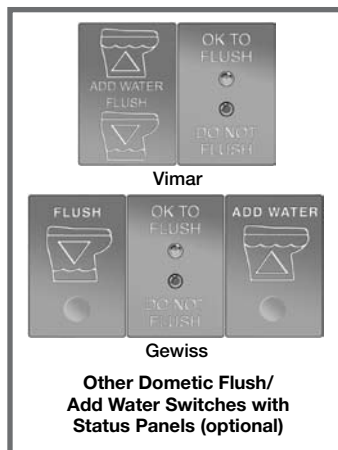

SERVICE MODE

To clean toilet bowl or perform other service that requires keeping the flush ball open without running water, locate the Service Mode switch at the back left side of the seat mounting bracket. Slide the switch to the right. (On some models the Service Switch is a toggle type that's located on the check valve of the toilet. It can be reached behind the left side of the toilet bowl. See page 11 for location.) Press the toilet's Flush switch until the flush ball opens, then release it to keep the flush ball open. Perform the service operation. To close the flush ball and return to Normal operation, slide the Service Mode switch to the left.

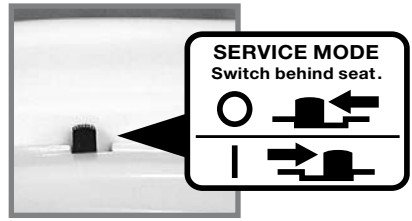

PROPER BOWL CLEANING

For stubborn bowl stains, use SeaLand® Toilet Bowl Cleaner (Fig. A). It's manufactured especially for use with all SeaLand toilets. In certain locations where water is hard, a build-up of lime may dull the toilet bowl finish. Restore the shine with this SeaLand cleaner. If you cannot find it in your area, contact Dometic for your nearest dealer. If the cleaner is not available, you can also use most non-abrasive bathroom and toilet bowl cleaners (Bar Keeper's Friend® spray cleaner, Clorox® toilet bowl cleaner, SaniFlush® toilet bowl cleaner, etc.). Please follow label instructions.



To avoid damaging the Teflon®-coated seal,

DO NOT USE:

- abrasives (Comet®, Soft Scrub® cleansers etc.)
- caustic chemicals (Drano® clog remover, etc.)
- lubricants and cleaners containing alcohols or petroleum distillates (Pam® cooking spray, Pine-Sol® cleaner, WD-40® lubricant, etc.).

- ® Bar Keepers Friend is a registered trademark of SerVaas Laboratories Inc.
- ® Clorox, Pine-Sol and Soft Scrub are registered trademarks of The Clorox Co.
- ® Comet is a registered trademark of Prestige Brands International.
- ® Drano is a registered trademark of S.C. Johnson & Son Inc.
- ® Pam is a registered trademark of ConAgra Foods.
- ® Sani-Flush is a registered trademark of Reckitt Benckiser Inc.
- ® Teflon is a registered trademark of DuPont Co.
- ® WD-40 is a registered trademark of WD-40 Company.

EXTENDED PERIODS OF NON-USE - CLEARING DISCHARGE LINES

Toilet system sanitation hoses should be cleared if toilet will not be needed for an extended period of time (more than two weeks).

1. Fill toilet bowl with water and add 4 oz. (120 ml) of biodegradable laundry detergent (should NOT contain bleach).
2. Open flush ball in Service Mode (see directions above). Hold the Add Water switch down for about two minutes. Release the Add Water switch and return the Service Mode switch to the Normal position.
3. Turn off water supply to toilet.
4. Flush the toilet without water, allowing the vacuum pump to shut off after the flush. Repeat three times. (This procedure will minimize any remaining water in the sanitation hoses.)
5. Turn off power to the vacuum pump.
6. Completely pump out holding tank.

If system will be subjected to freezing temperatures, please follow above procedure, then winterize system as described on next page.

TURN OFF ELECTRICITY AND WATER TO TOILET IF IDLE FOR LONG PERIODS OF TIME

If people will not be using the boat for a long time (vacation, maintenance, off-season, etc.), or in the event of a long electrical power interruption, electrical power and water supply to the toilet and vacuum generator should be shut off.

WINTERIZING

At the end of each season, the VacuFlush toilet system should be winterized for storage. The following procedure should be used:

1. Pump out holding tank.
2. Thoroughly flush system with fresh water.
3. Drain freshwater tank.
4. Add freshwater antifreeze to freshwater tank.
5. Flush freshwater water antifreeze and water mixture through toilet and into the waste holding tank. Each installation is different, so amounts may vary. User discretion is required to assure adequate protection.
6. Empty holding tank.

NOTE: Use nontoxic antifreeze designated for potable water systems. (See vehicle owner's manual.)
Never use automotive-type antifreeze in freshwater systems.

MAINTAINING THE SYSTEM

Maintenance intervals and normal parts replacement vary widely depending on factors such as frequency of system use, quality of flushing water, etc. The chart below is intended as a general guide in keeping your sanitation system 100% ready for use at any time.

Maintenance Procedure	Service Interval	Additional Information
ROUTINE		
Check all clamped hose joints below water line for leaks.	Monthly	-
Check filter screen in water valve.	After first year of service, then as needed if water flow is noticeably slower.	Screen is located inside water valve inlet.
Replace vent filter (if installed in holding tank vent line).	Annually	-
MAJOR SYSTEM MAINTENANCE		
Replace duckbill valves in vacuum generator or vacuum pump.	Every three years	See vacuum generator or vacuum pump parts list for replacement kit part number.
Replace flush ball seal and flush ball (if required).	Every three years	See toilet parts list for replacement kit part number.

SPARE PARTS

Boats operating in remote waters should carry the following parts on board.

Description	Where Used
Flush ball seal	4800 series vacuum toilet. See parts list.
Flush ball	4800 series vacuum toilet. See parts list.
Electric water valve	4800 series vacuum toilet. See parts list.
Vacuum switch kit	Vacuum tank or vacuum generator. See parts list.
Duckbill valves	Vacuum pump or vacuum generator. See parts list.

ORDERING PARTS

Dometic is ready to assist you in the event service is required. Before calling, please have the following information available. Your cooperation in having this information ready is appreciated and allows us to better meet your needs. Please refer to Customer Service section in this manual.

1. Toilet Model Number (See Toilet Model Identification section, page 3.)
2. Serial Number
3. Part Number, Description and Quantity (see separate parts list sheet.)

INSTALLATION – GENERAL INFORMATION

Special Installation Notes

1. Each 4800 series toilet installation must include a separate vacuum generator or vacuum pump/tank combination (available separately).
2. See WARNINGS on page 3 for additional toilet system installation and operation information.

Flush Water Options

FRESH WATER SYSTEM – VacuFlush vacuum toilets can flush with fresh water or sea water. Fresh water is highly recommended because it reduces odors often associated with sea water and reduces system maintenance.

INSTALLATION NOTES

- Use cold water only.
- Water supply line: 1/2-in. (13mm) ID; toilet inlet fitting is 1/2-in. (13mm), 14 TPI.
- Requires 2.0 GPM (7.6 LPM) flow rate at toilet water valve.
- Include shut-off valve in water line for maintenance purposes.

RAW WATER SYSTEM – VacuFlush vacuum toilets can flush with sea water but require a separate pump and water filtration for this purpose. Please contact your nearest VacuFlush dealer, distributor, or Dometic Sanitation sales office for complete information.

INSTALLATION NOTES

- See Notes from Freshwater System (above).
- Seacock must be full-flow, marine quality valve (not screw-to-close type).
- Use primary and secondary raw water filters (see illustration).
- Position vented loop between discharge side of water pump and toilet. Must be equipped with integral check valve that permits air into line to prevent siphoning.

Vented loop must be at least 8 inches [203mm] above water line in toilet during all conditions of heel, trim or load.

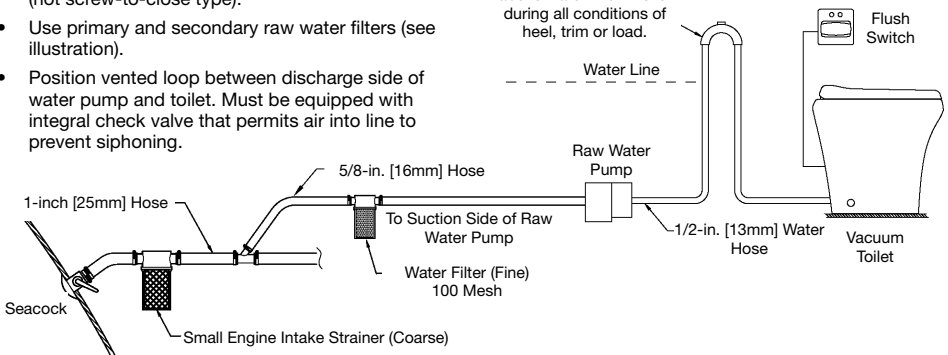

Discharge Piping (see System Layout, page 4)

HORIZONTAL AND VERTICAL RUNS – All discharge piping and seacocks (including seacocks) must be 1.5-inch (38 mm) ID nominal pipe size. Maximum vertical piping from toilet outlet to vacuum source inlet is 6 feet (1.8 meters). Maximum horizontal length of vacuum piping from toilet outlet to vacuum source is 50 feet (15 meters). Other restrictions on discharge piping apply. Contact your nearest VacuFlush dealer, distributor, or Dometic Sanitation customer service for more information.

INSTALLATION - GENERAL INFORMATION (cont'd)

Discharge Piping Layouts

VacuFlush toilets must be connected to 1.5-inch (38mm) ID flexible sanitation hose. Connections can be made either through the floor or out the rear of the toilet above the floor.

Flexible hoses that contain sewage from any marine toilet will create unpleasant odor that permeates through the wall of the hose. Avoid this condition by installing the tank in the lowest position in the boat so that hose contents will drain into the holding tank. Rigid PVC pipe can also be installed in runs that hold trapped sewage. The marine sanitation hose most resistant to odor permeation is OdorSafe Plus® hose, available from your local SeaLand or VacuFlush product dealer.

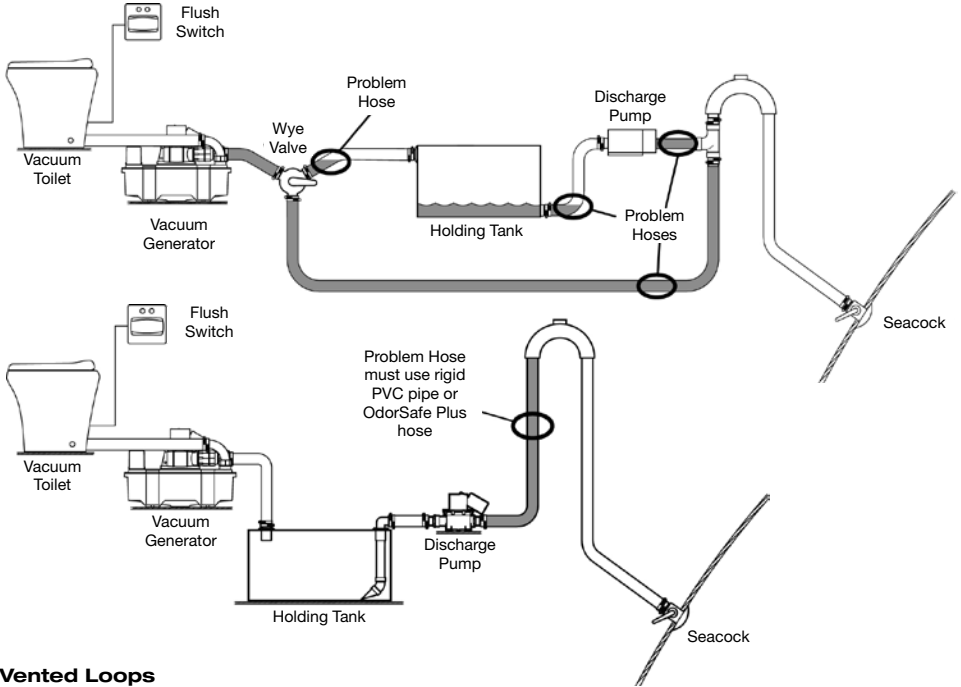

Vented Loops

Ventilated or vented loops are intended to prevent back siphonage of sea water into the toilet. If the toilet rim is below the waterline at ANY time in ANY conditions of heel, load or trim, a vented loop MUST be installed in the hose run at a point at least 8-in. (203 mm) above the toilet water line in all such conditions. See vented loop fitting manufacturer's recommendation for further information.

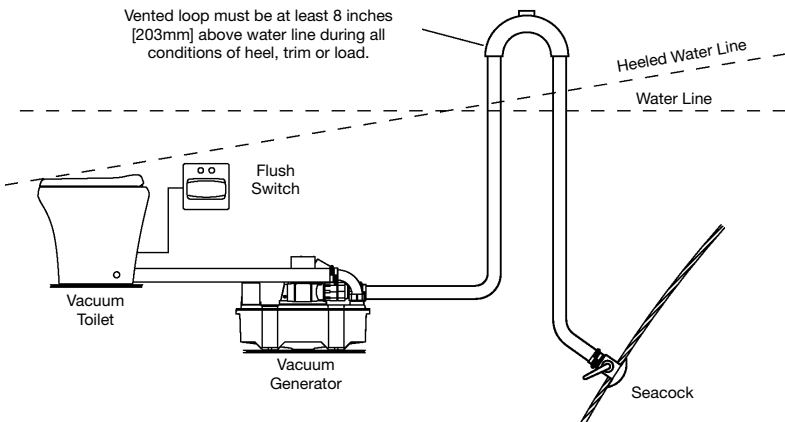

INSTALLATION – GENERAL INFORMATION (cont'd)

Holding Tanks

VacuFlush toilets operate with most holding tank or treatment systems. When installed with a holding tank, the maximum capacity of the tank should be large enough to avoid the inconvenience of frequent discharges. A 30-gallon tank (114-liter) will become full in about 90 flushes.

Electrical Requirements

Refer to wiring diagram on Parts List/Wiring Diagram sheet (shipped with toilet).

Seacocks

Seacocks are required by various marine regulations. Only full-flow, marine quality valves are recommended. Some regulations require the seacocks be configured so they can be locked in a closed position. Seacocks **MUST** be installed according to the manufacturer's instructions.

Toilet Installation

See Toilet Mounting Template and instructions on separate sheet (supplied with toilet).

DEODORANTS AND SPECIAL TISSUE

Your VacuFlush toilet system may require the regular addition of a deodorant product to reduce malodors and to help break down holding tank contents. Several factors should be considered in selecting a deodorant product.

Liquid or Granulated. Liquid products work more quickly by readily going into solution. Granulated powder formulations have the advantage of requiring less storage space and are less likely to leak if the package is inadvertently damaged.

Formaldehyde versus Non-Formaldehyde. Dometic manufactures both types of deodorants. Generally speaking, formaldehyde formulas control odor very effectively at all temperatures and with all degrees of water hardness. Both SeaLand® Environment-Friendly and Clean 'n Green™ brands, which are formaldehyde-free, are similarly effective.

How Much Deodorant and How to Add It. The deodorant is added directly into the toilet bowl, then flushed into the holding tank. Follow bottle or package instructions. Conditions of extremely warm weather, longer waste holding time and larger tank capacities may require more deodorant treatment. Also, to maintain optimum efficiency in odor control, the waste holding tank should be cleaned thoroughly at least once or more each season depending on use.

Why Not Use Household Toilet Paper in Your Toilet. Household tissues often contain adhesives which bond together the paper fibers from which the tissue is made. The adhesives prevent the tissue from breaking apart, and their use in "ultra-low flow" systems can cause system clogging. SeaLand tissue is especially designed for use in low water toilet systems. Its rapid-dissolving properties minimize the amount of residual paper in the holding tank and allow deodorizers to work more efficiently.

SeaLand Brand versus Other Brands. We constantly strive to provide our system owners with effective products that have minimal environmental impact and good value. Many deodorant products do not measure up to our standards of performance and value.



SeaLand®
Rapid-Dissolving
Toilet Tissue
Four 400-sheet rolls
Part No. 379441204

SeaLand®
Cleaner
16-oz. bottle
Part No. 379314016

SeaLand®
Clean 'n Green
Bowl Cleaner/Tank Deodorant
12-2 oz. drop-in pouches
Part No. 379512602

SeaLand® Liquid
Deodorant -
Environment Friendly
32-oz. bottle
Part No. 379114032

TROUBLESHOOTING GUIDE

Toilet base assembly

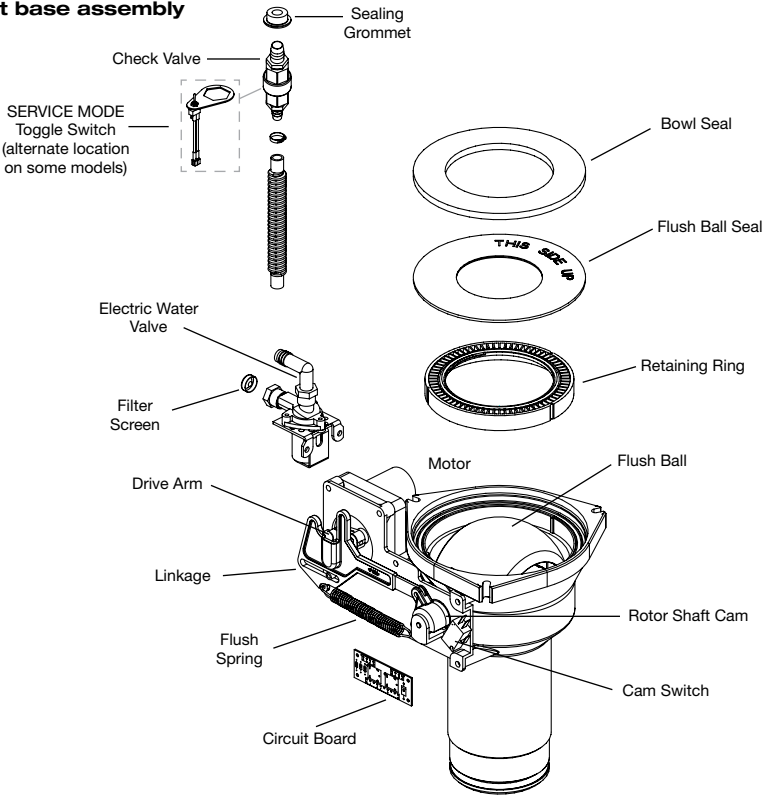

Problem	Possible Cause	Service Instructions
1. Water does not enter bowl and toilet does not flush.	<ul style="list-style-type: none"> a. Toilet fuse is blown or circuit breaker is tripped. b. Loose wiring connections. c. Incorrect wiring of toilet to incoming power. d. Defective circuit board. 	<ul style="list-style-type: none"> a. Check toilet fuse or circuit breaker. b. Check for loose or defective wiring at circuit board pins 9 and 10. c. Check for reverse polarity of incoming power. d. Replace circuit board.
2. Water enters toilet bowl, but toilet does not flush.	<ul style="list-style-type: none"> a. Electrical failure from flush switch to toilet. b. Flush switch may be defective. c. Loose flush ball motor wires. d. Defective flush ball motor. e. Flush ball motor drive arm failure. f. Drive linkage failure. g. 4800L & 4800WL series require "OK to Flush" light to be lit for toilet to flush. 	<ul style="list-style-type: none"> a. Check for loose or defective wiring between flush switch and circuit board pins 2 and 4. b. Replace if necessary. c. Check for loose wires between motor and circuit board pins 17 and 18. d. Replace if necessary. e. See page 15 for replacement instructions. f. See page 15 for replacement instructions. g. Check for loose or defective wires between vacuum switch on vacuum generator and pin 6 of circuit board.

TROUBLESHOOTING GUIDE (cont'd)

Problem	Possible Cause	Service Instructions
3. Water does not enter toilet bowl, but toilet flushes.	a. Blocked water supply. b. Loose or defective wiring. c. Defective water valve. d. Defective circuit board.	a. Clear blockage in water line or filter screen at water valve inlet. b. Check wiring between water valve and circuit board pins 15 and 16. c. Replace if necessary. d. Replace circuit board.
4. Water does not enter toilet in "Add Water" switch position.	a. Electrical failure. b. Defective flush switch.	a. Check for loose or defective wiring between flush switch and circuit board pins 1 and 4. b. Replace if necessary.
5. Water does not shut off and toilet bowl overflows.	a. Debris inside water valve or defective water valve.	a. Replace water valve.
6. Flush ball cycles constantly between open and closed positions.	a. Electrical short circuit. b. Cam switch needs adjustment to align flush ball. c. Defective cam switch. d. Defective drive linkage.	a. Check wiring between flush switch and circuit board pins 1 and 4. b. See page 14 for cam switch adjustment/flush ball alignment. c. Replace cam switch. See page 15 for replacement details. d. Replace drive linkage. See page 15 for details.
7. Flush ball opens slowly.	a. Excessive drag between flush ball and seal. b. Defective spring assembly.	a. Clean surface of flush ball and under edge of seal. Lubricate with alcohol-free cooking spray. b. Replace spring.
8. Flush switch must be held in FLUSH position to close flush ball.	a. Loose or defective wiring. b. Defective cam switch. c. Service Mode switch is in Service position.	a. Check wiring between cam switch and circuit board pins 11 and 12. b. Replace cam switch. See page 15 for details. c. Return Service Mode switch to Normal position.
9. Flush ball does not close completely.	a. Cam switch needs adjustment/flush ball alignment or replacement. b. Rotor cam shaft loose or defective.	a. See adjustment/alignment or replacement details on page 14. b. See replacement instructions on page 15.
10. Flush ball does not open completely.	a. Rotor cam shaft is loose or defective. b. Weak or defective spring assembly. c. Excessive drag between flush ball and seal.	a. See instructions for repair or replacement on page 15. b. Replace spring. c. Clean surface of flush ball and under edge of seal. Lubricate with alcohol-free cooking spray.
11. Squeaky noise occurs during flush cycle.	a. Lubrication needed between flush ball and seal. b. Lubrication needed between drive arm/linkage joint.	a. Lubricate with alcohol-free cooking spray. b. Lubricate joint with silicone grease.

TROUBLESHOOTING GUIDE (cont'd)

Problem	Possible Cause	Service Instructions
12. Water does not stay in toilet bowl (leaks between flush ball and seal).	<ul style="list-style-type: none"> a. Flush ball seal is worn and needs replaced. b. Flush ball is scratched or worn and needs replaced. c. Cam switch/flush ball alignment needs adjustment. d. Bolts that hold base to toilet need tightened to 20-25 in.-lbs. 	<ul style="list-style-type: none"> a. See instructions on page 15 for replacement. b. See instructions on page 15 for replacement. c. See instructions on page 14 for adjustment. d. DO NOT OVERTIGHTEN or damage to toilet may occur.
13. Toilet flushes in both ADD WATER and FLUSH position.	<ul style="list-style-type: none"> a. Defective circuit board. 	<ul style="list-style-type: none"> a. Replace circuit board.
14. Water leaks from toilet onto floor.	<ul style="list-style-type: none"> a. Loose water line connection. b. Defective water valve. c. Toilet bowl seal is defective. d. Mounting bolts holding base to toilet need tightened to 20-25 in.-lbs. 	<ul style="list-style-type: none"> a. Tighten water line connections. b. Replace water valve. c. Replace bowl seal. See instructions on page 15. d. DO NOT OVERTIGHTEN or damage to toilet may occur.
15. Green OKAY TO FLUSH light does not illuminate.	<ul style="list-style-type: none"> a. Loose wire at circuit board. b. Loose wire at Flush Switch. c. Loose or defective wire between vacuum switch and toilet. d. Defective green light. 	<ul style="list-style-type: none"> a. Check wires at pins 3 and 6 of circuit board. b. Check green wire at Flush Switch. c. Repair or replace wires. d. Replace Status Panel.
16. Red DO NOT FLUSH light does not illuminate.	<ul style="list-style-type: none"> a. Loose wire at circuit board. b. Loose wire at Flush Switch. c. Loose or defective wire between vacuum switch and toilet. d. Loose or defective wire between tank FULL relay and toilet circuit board pin 8. e. Defective red light. 	<ul style="list-style-type: none"> a. Check wires at pins 5, 7 and 8 of circuit board. b. Check red wire at Flush Switch. c. Repair or replace wires. d. Repair or replace wire. e. Replace status panel.
17. Flush ball opens and closes, but waste does not leave bowl (no vacuum).	<ul style="list-style-type: none"> a. No electrical power to vacuum pump. b. Tank FULL shut-down relay prevents vacuum pump from operating. c. Blockage inside bottom of toilet base. 	<ul style="list-style-type: none"> a. Check power wires, fuse or circuit breaker to vacuum pump. b. Pump out holding tank. c. See instructions below to clear blockage.

Clearing Blockage in Toilet Base

1. Turn off water to the toilet.
2. Open the flush ball in Service Mode.
3. Pull the foreign material from the 1-inch diameter orifice at the bottom of the base or, using a small diameter blunt rod, attempt to push the blockage through the orifice.

Locating Potential Vacuum Leaks in Toilet Base

The VacuFlush toilet is part of a vacuum system that includes a vacuum pump and vacuum tank, or a vacuum generator and discharge plumbing lines. If a vacuum leak is suspected, special equipment will isolate the source of the leak. If the toilet is determined to be the source of the leak, there are three possible areas to investigate:

1. Flush ball and flush ball seal. See Problem 12 in Troubleshooting Guide.
2. O-rings on the rotor shaft.
3. O-rings around bottom of toilet base assembly.

Sources 1 and 2 will require the base assembly to be removed from the toilet and partially disassembled.

TROUBLESHOOTING GUIDE (cont'd)

Adjusting cam switch/flush ball alignment

The flush ball should be properly positioned so that the "A" and "B" distances are equal (see illustration at right). If the flush ball becomes misaligned (resulting in water leaking from bowl or other flushing problems), follow instructions below to resolve problem.

REMOVING TOILET FROM FLOOR

1. Turn off water and electrical power to toilet.
2. Remove water inlet hose from toilet.
3. Remove toilet from floor and turn it upside down. **MAKE SURE POWER WIRES REMAIN SECURE.**

TO CORRECT PROBLEMS 6b, 9a and 12c:

4. Loosen cam switch mounting screws with 3/32-inch hex tool and 1/4-inch box-end wrench. Slide cam switch up or down (see illustrations below) depending on flush ball position.

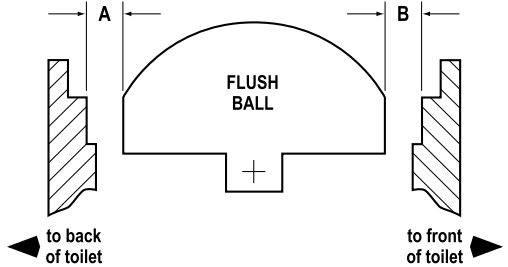

5. Tighten cam switch mounting screws, apply electrical power and check adjustment. Repeat as necessary.
6. After cam switch and flush ball are properly positioned, connect water line and reinstall toilet.

OVER-TRAVEL CONDITION

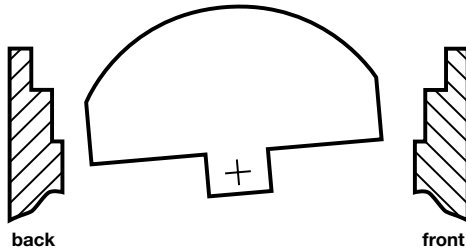

UNDER-TRAVEL CONDITION

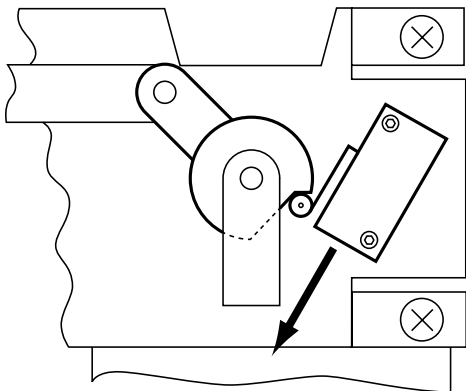
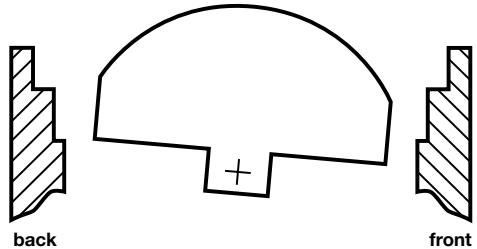

Slide cam switch down.

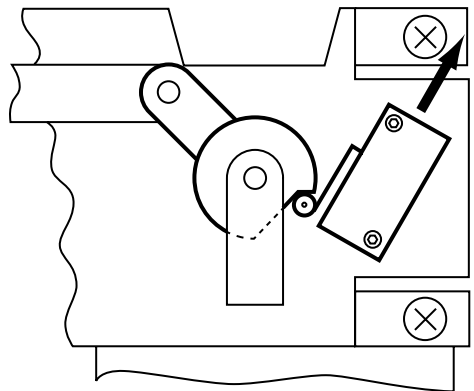

Slide cam switch up.

TROUBLESHOOTING GUIDE (cont'd)

Replacing the flush ball seal and bowl seal

1. Turn off water and electrical power to toilet.
2. Remove water inlet hose from toilet.
3. Remove toilet from floor and turn it upside down. Disconnect Service Switch wires at in-line connectors.
4. Remove three nuts and flat washers securing base assembly to toilet bowl using a 1/4-inch drive ratchet wrench, 7/16-inch deep-well socket and extension.
5. Pull check valve out of the sealing grommet located in rear of toilet bowl.
6. Lift base assembly from toilet.
7. Replace old seals with a complete seal kit.
8. Reconnect base assembly to toilet with new mounting bolts (L-shaped) included with seal kit. Tighten nuts to 20-25 in.-lbs. torque.
9. Reconnect Service Switch wires. Reattach water inlet hose to toilet.
10. Reinstall toilet to floor.

Replacing the flush ball

1. Turn off water to toilet.
2. Open flush ball in Service Mode, then turn off power to toilet.
3. Disconnect water inlet hose.
4. Remove toilet from floor and turn upside down, and disconnect Service Switch wires at in-line connectors.
5. Pull check valve out of sealing grommet located in rear of toilet bowl.
6. Remove three nuts and flat washers securing base assembly to ceramic toilet bowl using a 1/4-inch drive ratchet wrench, 7/16-inch deep-well socket and extension.
7. Lift base assembly from toilet.
8. Remove bowl seal, flush ball seal, and retainer plate to expose flush ball.
9. Loosen set screw in the rotor shaft cam using a 1/8-inch hex tool.
10. Remove the #8 x 1/4-inch long screw and flat washer from linkage slot.
11. Remove the four screws securing the mounting bracket to base.
12. Pull mounting bracket and rotor cam off base.
13. Rotate flush ball forward and remove flush ball retaining screw.
14. Replace flush ball and reverse disassembly through step 10.
15. Push rotor cam all the way onto rotor shaft. Tighten set screw.
16. Lubricate moving parts with silicone grease.
17. Before reassembling entire toilet, the cam switch may require adjustment. See "Adjusting The Cam Switch" on page 14.

Replacing the rotor shaft

1. Follow disassembly steps 1 through 14 under "Replacing the Flush Ball".
2. Pull rotor shaft out from inside of the base.
3. Lubricate O-rings on new shaft with silicone grease.
4. Align flat section on rotor shaft with flat section in cam during assembly. Push rotor shaft cam fully onto rotor shaft. Tighten set screw.
5. Lubricate moving parts with silicone grease.
6. Reverse the disassembly procedure.
7. Before attaching base to toilet, the cam switch may require adjustment. See "Adjusting The Cam Switch" on page 14.

Replacing the rotor shaft cam

1. Follow disassembly steps 1 through 14 under "Replacing the Flush Ball".
2. Remove linkage pin clip and pin.
3. Attach new rotor shaft cam to linkage using pin and clip.
4. Lubricate moving parts with silicone grease.
5. Reverse the disassembly procedure.
6. Before attaching base to toilet, the cam switch may require adjustment. See "Adjusting The Cam Switch" on page 14.

Replacing the motor drive arm

1. Follow disassembly steps 1 through 11 under "Replacing the Flush Ball".
2. Remove the four motor mounting screws.
3. Remove the motor from the mounting bracket.
4. Loosen the Drive Arm set screw using a 3/32-inch hex tool, then remove old Drive Arm.
5. Install new Drive Arm and push onto motor shaft as far as possible. Tighten the set screw.
6. Lubricate moving parts with silicone grease.
7. Reverse disassembly procedure.
8. Before attaching base to toilet, the cam switch may require adjustment. See "Adjusting The Cam Switch" on page 14.

Replacing the drive linkage

1. Follow disassembly steps 1 through 13 under "Replacing The Flush Ball".
2. Remove linkage pin clip and pin at rotor shaft cam.
3. Remove the flush spring retaining screw and washer from the retaining post.
4. Remove the flush spring from the old linkage.
5. Insert the flush spring into the new linkage and reattach the spring to the retaining post.
6. Attach linkage to rotor shaft cam using pin and clip.
7. Lubricate moving parts with silicone grease.
8. Reverse the disassembly procedure.

CUSTOMER SERVICE

There is a strong, worldwide network to assist in servicing and maintaining your sanitation system. For the Authorized Service Center near you, please call from 8:00 a.m. to 5:00 p.m. (ET) Monday through Friday.

You may also contact or have your local dealer contact the Parts Distributor nearest you for quick response to your replacement parts needs. They carry a complete inventory for the SeaLand product line.

Telephone: 1 800-321-9886 U.S.A. and Canada
330-496-3211 International

Fax: 330-496-3097 U.S.A. and Canada
330-496-3220 International

Website: <http://www.DometicSanitation.com>
<http://www.DometicSanitation.com/locate.asp>

MANUFACTURER'S ONE-YEAR LIMITED WARRANTY

Dometic Corporation warrants, to the original purchaser only, that this VacuFlush vacuum discharge toilet, if used for personal, family or household-like purposes, and if installed according to Dometic's recommended procedures, is free from defects in material and workmanship for a period of one (1) year from the date of purchase.

If this Dometic product is placed in commercial or business use, it will be warranted, to the original purchaser only, to be free of defects in material and workmanship for a period of ninety (90) days from the date of purchase.

Dometic reserves the right to replace or repair any part of this product that proves, upon inspection by Dometic, to be defective in material or workmanship. All labor and transportation costs or charges incidental to warranty service are to be borne by the purchaser-user.

EXCLUSIONS

IN NO EVENT SHALL DOMETIC BE LIABLE FOR INCIDENTAL OR CONSEQUENTIAL DAMAGES, FOR DAMAGES RESULTING FROM IMPROPER INSTALLATION, OR FOR DAMAGES CAUSED BY NEGLIGENCE, ABUSE, ALTERATION, OR USE OF UNAUTHORIZED COMPONENTS. THIS INCLUDES FAILURES WHICH MAY RESULT FROM NOT FOLLOWING THE WINTERIZATION OR CLEANING PROCEDURES AS DESCRIBED IN THIS MANUAL. ALL IMPLIED WARRANTIES, INCLUDING ANY IMPLIED WARRANTY OF MERCHANTABILITY OR FITNESS FOR ANY PARTICULAR PURPOSE, ARE LIMITED TO A PERIOD OF ONE (1) YEAR FROM DATE OF PURCHASE.

IMPLIED WARRANTIES

No person is authorized to change, add to, or create any warranty or obligation other than that set forth herein.

Implied warranties, including those of merchantability and fitness for a particular purpose, are limited to one (1) year from the date of purchase for products used for personal, family or household-like purposes, and ninety (90) days from the date of purchase for products placed in commercial or business use.

OTHER RIGHTS

Some states do not allow limitations on the duration of an implied warranty, and some states do not allow exclusions or limitations regarding incidental or consequential damages; so, the above limitations may not apply to you. This warranty gives you specific legal rights, and you may have other rights which vary from state to state. To obtain warranty service, first contact your local dealer from whom you purchased this product.

Dometic is a customer-driven, world-leading provider of innovative leisure products for the caravan, motor-home and marine markets. Dometic offers a complete range of air conditioners, refrigerators, awnings, cookers, sanitation systems, lighting, windows, doors and other equipment that makes leisure life more comfortable away from home.

Dometic also provides refrigerators for specific use in hotel rooms, offices and for storage of medical products and wine. Dometic's products are sold in almost 100 countries and are produced mainly in Dometic's own production facilities around the world. Dometic has more than 4,400 employees.

® Registered; ™ Trademark of Dometic Corporation
© Dometic Corporation
600345371 2/08